

5' Classic Roller Kite

©2009 Kevin Shannon

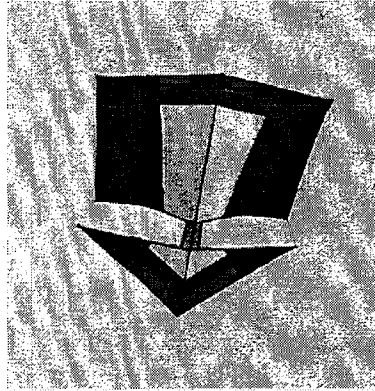

- Materials:**
- | | |
|------------------------------------|---|
| 50" x 54"-56" ripstop nylon | 3 - 1880 x 48" pultruded carbon tube |
| 6" x 4" 3 oz. Dacron, Black | 1 - 2540 x 60" pultruded carbon tube or 2 - 48" |
| 18" x 1" lightweight webbing | 1 - 3/32" x 10" fiberglass or carbon rod |
| 3 - 1 1/2" squares adhesive Dacron | 6" of fl248 fiberglass tube (optional) |
| 30' x 1" 3/4" ripstop edge binding | 1 - 2540 ferrule (optional w/60" carbon tube) |
| 3" x 3/4" or 1" Velcro | 12" - 3/16" ID x 5/16" OD vinyl tubing |
| 2 - 1/4" dihedrals | or 4 APA micro LE fittings, .180-.188 |
| 4 - 3/16" end caps | 1 - 1/8" or 1/4" grommet |
| 2 - 1/4" end caps | 15' - 100# test Dacron line |
| 2 - 3/32" end caps | superglue |
| 1 - 1" aluminum ring | |

Sail Preparation:

Cut out of 3/4oz ripstop:

- 2- top sail
- 1- rudder
- 2- batten sleeves (5/8" x 14")

- 2- bottom sail
- 2- connecting sleeve parts (4" x 7" & 4" x 6")
- 1- strip black ripstop (3/4" x 20")

Cut out of 3 oz. Dacron:

- 1 reinforcement patch, 1" square

Cut out of insignia cloth: (3oz. adhesive Dacron)

- 3 reinforcement patches, 1 1/2" square

Tri fold the 3/4" x 20" black ripstop to form a piece 1/4" x 20"

Sew down the middle of the strip with a straight stitch.

Cut into 3/4" x 3" pieces to use as loops

Pocket Preparation:

- 1) Fold the 6" x 4" 3oz. black Dacron in half so that the finished piece is 3" x 4" with the fold at the top, along the 4" dimension.
- 2) Hot cut 2 strips, 1 1/8" x 3" out of the folded Dacron.

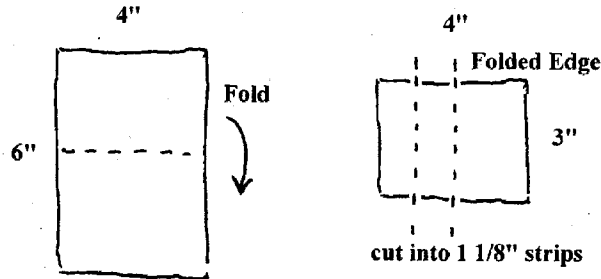

Top Pocket: Fold over and crease the top 1".

Bottom Pocket: Fold over and crease the top 1". Sew a piece of Velcro to the top of this piece. Sew the matching piece of Velcro to the middle of the piece, about 3/4" up from the bottom. NOTE: sew only along the sides of this bottom piece of Velcro so that it forms a tunnel through which the center spine may pass.

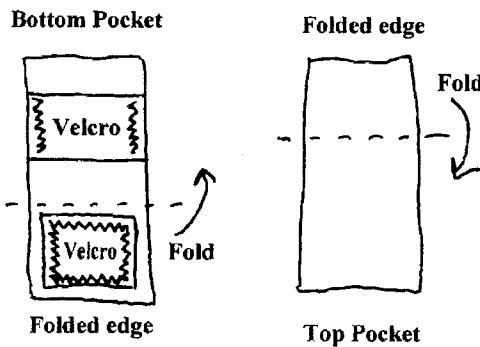

Side Pockets: From the 1" wide lightweight webbing, hot cut 2 pieces 3 1/2" long (top spreaders) and 2 pieces 2 1/4" long (bottom spreaders). Fold over and crease 1 1/2" on the top spreaders and 3/4" on the bottom spreaders.

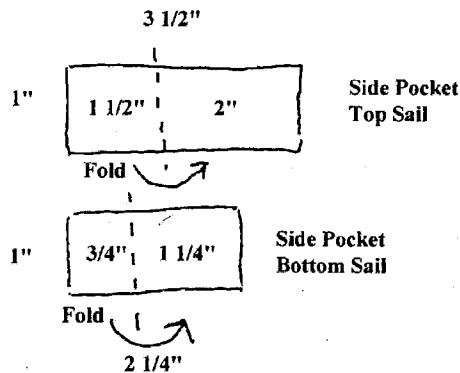

Lay pockets aside for later.

Rudder:

- 1) Cut one of the insignia cloth patches in half diagonally. Position the triangular patches on both sides of the rudder at the 90° corner.

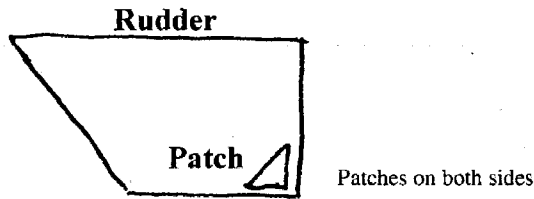

- 2) Edge bind the 3 short sides of the rudder, leaving the side that is sandwiched between the bottom sails unbound.
- 3) Fold a 3" section of the tri-fold ripstop in half and position on the 90° corner of the rudder and sew to form a tow loop.
- 4) Take each batten strip and fold over about 1 1/2" to form strips that are 5/8" x 12 1/2".
- 5) Position each batten sleeve on either side of the rudder so that they lay diagonally opposite the tow loop.
- 6) Sew along the edges of the batten sleeves, 1/8" in from the edge, leaving a break in stitching at the upper edge of the bottom corner to allow for insertion of the batten.

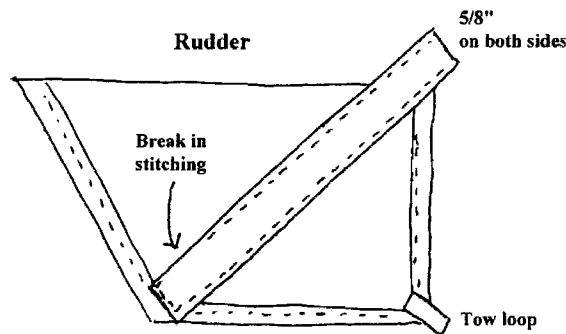

Connecting Sleeve:

- 1) Center the 4"x6" ripstop on top of the 4"x7" ripstop so that there is 1/2" of the 7" piece exposed above and below the 6" piece.
- 2) Sew the 2 pieces together with 2 rows of stitching, each 1/2" on either side of the centerline. This forms a sleeve for the spine to pass through.
- 3) Edge bind both 7" sides of the connecting sleeve. Leave the top and bottom 4" sides unbound.

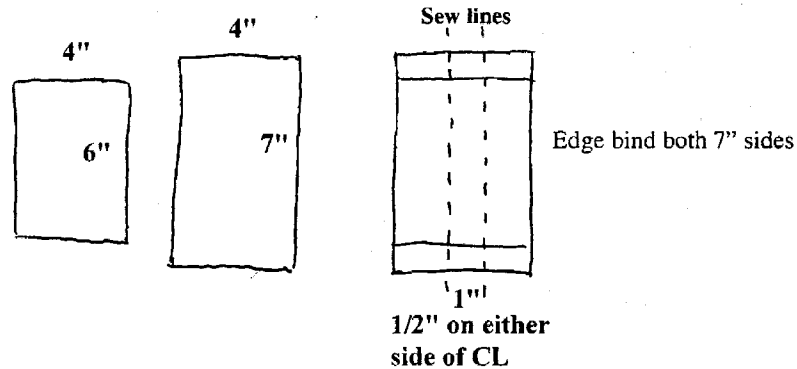

Top Sail:

- 1) Lay the top sails together, right sides facing, and sew along the center, 1/4" in from the edge.
- 2) Open up the sails, fold the seam to one side, and sew the seam flat.
- 3) Cut 2 of the insignia cloth patches in half diagonally.

- 4) At each of the bottom outside corners, place an insignia cloth triangle patch on both the front and back sides of the top sail.

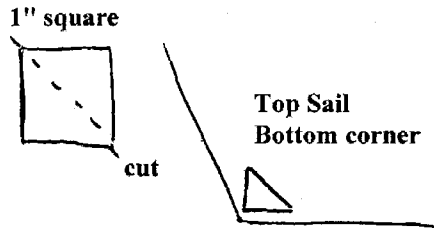

- 5) Edge bind all 5 sides of the top sail.
 6) Position the 1" square Dacron reinforcement patch on the center seam on the **back** of the top sail. The center of the patch should be 6" from the top. Sew the patch to the sail.
 7) Insert a grommet in the center of the reinforcement patch, along the center seam.

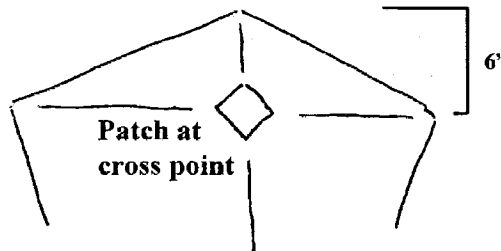

- 8) Position and sew the top pocket to the top center point of the top sail. Use a straight stitch and sew along all sides **except** the folded edge at the very top.
 9) Position and sew the side pockets. The folded edge should be centered on the very point where the top edge meets the side edge of the sail. Use a straight stitch and sew along all sides **except** the folded edge at the edge of the sail.

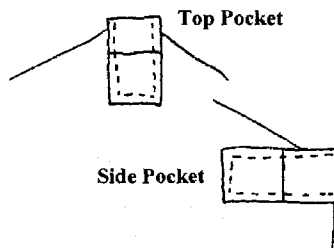

- 10) On the back of the top sail, fold and sew a piece of the 3" tri-fold ripstop to each bottom corner to form loops for the lines that connect the top and bottom sails.

Bottom Sail:

- 1) Lay the bottom sails together, right sides facing, with the rudder sandwiched between them. The back of the rudder needs to be 2 1/2" from the end of the bottom panels to allow for the bottom pocket. Sew the 3 panels together along the center, 1/4" in from the edge.

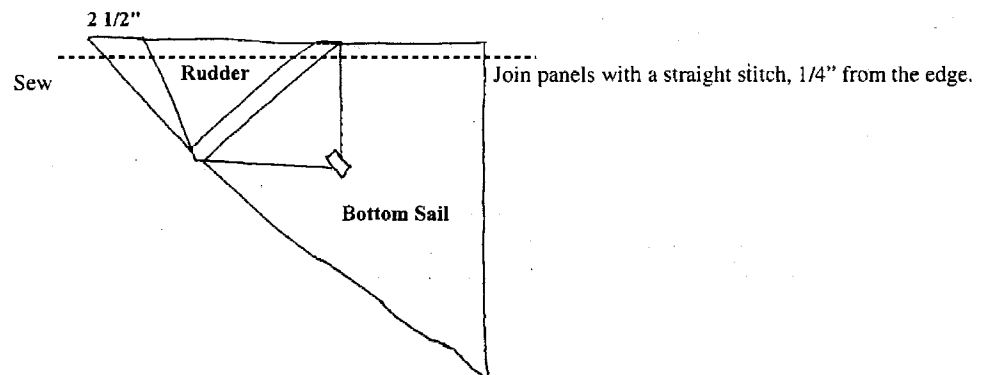

- 2) Open up the sails, fold the seam to one side, and sew the seam flat. Make sure to fold the rudder out of the way so that it doesn't get caught in the stitches.
- 3) Edge bind all 3 sides of the bottom sail.
- 4) On the outside tips of the bottom sail, fold the points back $\frac{3}{4}$ " along the diagonal edge toward the bottom center.

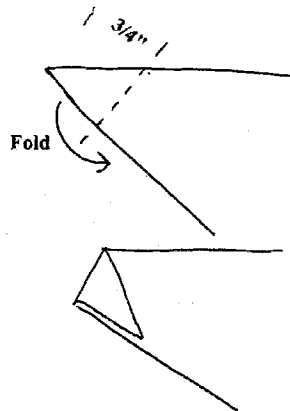

- 5) Position the bottom horizontal pockets at the outside tips of the bottom sail. Lay the outside edge of each pocket so that it aligns with the diagonal side of the sail. The inside corner of each pocket should project above the top straight edge of the bottom sail.
- 6) Sew the pockets to the sail along the outside edge, along the short edge, back up the other side **UNTIL** you reach the top edge of the bottom sail. Sew across the pocket following the top edge of the bottom sail. You'll now have a triangular pocket with the excess above the top edge of the bottom sail. See the illustration for clarification.
- 7) With a small pencil soldering iron, carefully burn a small hole in the center of the part of the pocket that projects above the top edge of the bottom sail. **Alternately**, you could sew a piece of the 3" tri-fold ripstop to each pocket, matching what you did for the bottom corners of the top sail.
- 8) Sew the bottom pocket (with Velcro closure) to the bottom center of the bottom sail. Be careful not to close off the tunnel formed by the one piece of Velcro.

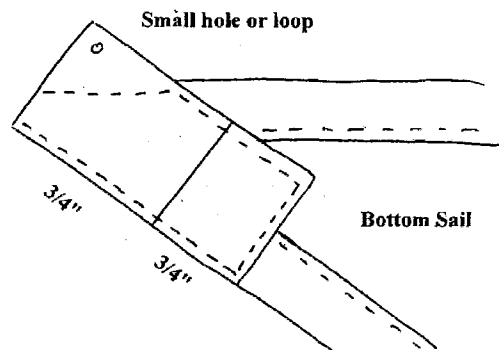

Joining the Sails:

- 1) Sew the connecting sleeve to the back bottom center of the top sail. The connecting sleeve should overlap the edge binding exactly. Make sure that the 6" (shorter) piece is facing rearwards so that the spine can pass through the sleeve.
- 2) Sew the other end of the connecting sleeve to the back top center of the bottom sail. Again, the connecting sleeve should overlap the edge binding exactly. Make sure that the 6" (shorter) piece is facing rearwards so that the spine can pass through the sleeve.

Spars and Final assembly:

- 1) Trim the 2540 carbon tube spine to length. Make sure that the spine goes through the tunnel in the connecting sleeve. Before adding the end caps, put 2- $\frac{1}{4}$ " dihedrals on the spine. One of the dihedrals on the top sail portion of the spine and one on the bottom sail portion of the spine.
Optional – Cut the full-length spine into 2 pieces and join with a ferrule so that the kite can be transported in a smaller package.
- 2) Cut and fit the top spreaders out of one of the 1880 carbon rods. It should be a tight fit with the end caps on, but not so much that it stretches the sail.

NOTE: In order to fit the spreaders into the dihedral fitting and into the pockets, you'll need to slid the dihedral fittings toward the bottom of the sail about 6". Put the spars in the dihedral fittings first, then put the ends with the endcaps into the pockets. Slide the dihedral fitting up into position.

- 3) Repeat step 2 with the bottom spreaders. These will be shorter than the top spreaders.
- 4) Cut the 3/16" ID vinyl tubing into 4 - 2" pieces. At the center of each piece, slit the vinyl halfway.

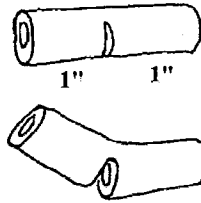

Vinyl Tubing

- 5) Slide a piece of the vinyl tubing onto each of the spreader spars. Bend the vinyl so that the spreader spar can enter through the slit at the center of the vinyl and exit from one of the ends. The part of the vinyl that doesn't have any of the spreader spar should point back towards the center of the kite.
- 6) Position each vinyl on the spreader spars so that the entry point of the spar, at the center of the vinyls, is 7 7/8" from the inside end of each spar. Super glue the vinyls so that they don't move from this location.

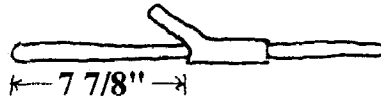

Optionally – Use the APA Micro LE fittings so that they are on the same place on each spar.

- 7) **Optional** – Cut 4 pieces of the fl248 tubing to 1" length. Super glue these pieces onto the inside end of each spreader spar so that they fit the 1/4" dihedrals better.
- 8) Cut 2 pieces of 1880 carbon tube to 15" for use as cross braces for the spreader spars.
- 9) Insert the cross braces into the vinyl tubings on the spreader spars, connecting each side of the top and bottom sail spars.
- 10) Cut the 3/32" fiberglass or carbon rod to length, install the end caps, and insert into the batten sleeve on the rudder.

Joining the Sails: Guy lines connecting the tips of the bottom sail to the lower corners of the top sail

- 1) For each side of the kite, cut a 20" piece of 100# Dacron line. Put an overhand loop on one end.
- 2) Feed the loop through the hole (or loop) on the overhanging side pocket on the bottom sail. Feed the other end of the line through the overhand loop and pull tight, putting a larks head knot over the pocket end.
- 3) Tie a loose half knot in the line about 4" from the bottom pocket.
- 4) Feed the free end of the line through the hole (or loop) in the bottom corner of the top sail, and through the half knot in the line. Pull the half-knot tight.
- 5) Repeat steps 2-5 on the other side of the kite.
- 6) On each guy line, adjust the length of the line through the half knot on the line so that the distance from the top sail to the bottom sail is the same distance as it is at the center of the kite,
- 7) Tie an overhand knot in the free end so that it rests against the half knot.
- 8) Adjust the position of this overhand knot on each guy line so that you maintain a constant distance between the top and bottom sail.
- 9) Trim the excess from each guy line.

See illustration on next page.

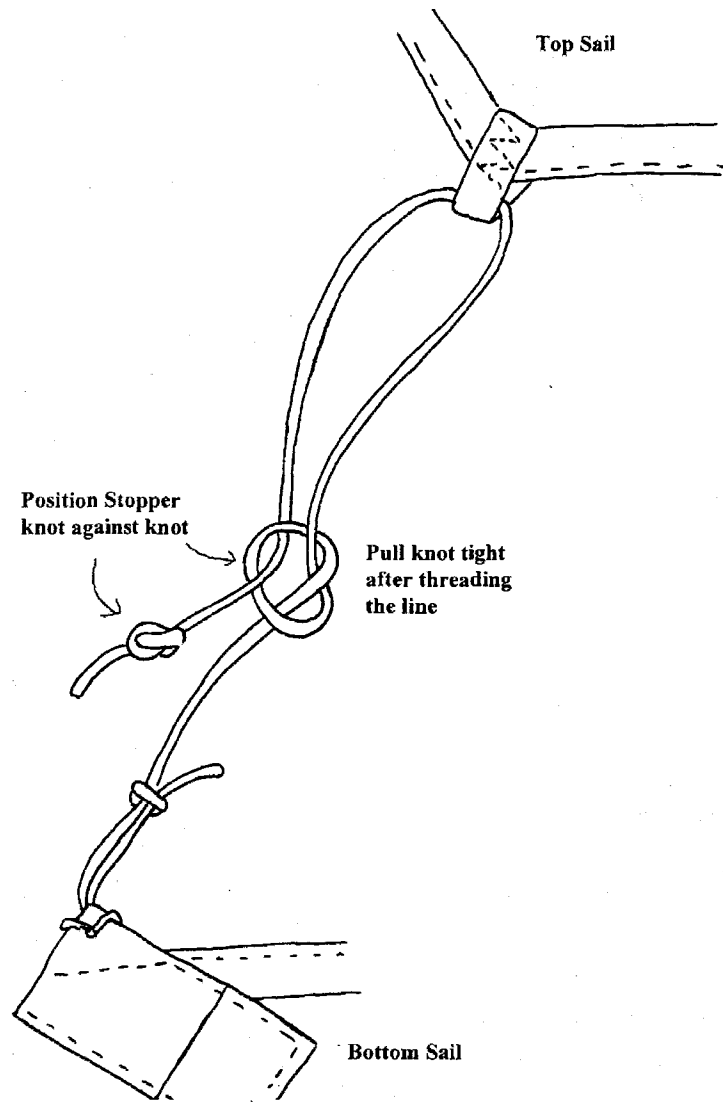

Attaching the bridle:

- 1) Cut a length of 100# Dacron line to about 120"
- 2) Put a 3" overhand loop on one end and a 6" loop on the other end.
- 3) Larks head knot the 3" loop through the tow loop on the rudder.
- 4) Feed the 6" end through the grommet on the top sail and larks head knot it around the spine and top dihedral fitting.
- 5) Attach the tow ring so that when the bridle is pulled out to one side, the tow ring is even with a point about 12" from the top of the kite.
- 6) Test fly to determine the optimum tow point.

5' Classic Roller Kite

©2009 Kevin Shannon

59"h x 48"w

Spine - 2540 carbon

Spreaders (light, w/spreader) - 1880 carbon
or

Spreaders (heavy, no spreader) - 2400 carbon

Rudder Batten - 3/32" fiberglass or carbon

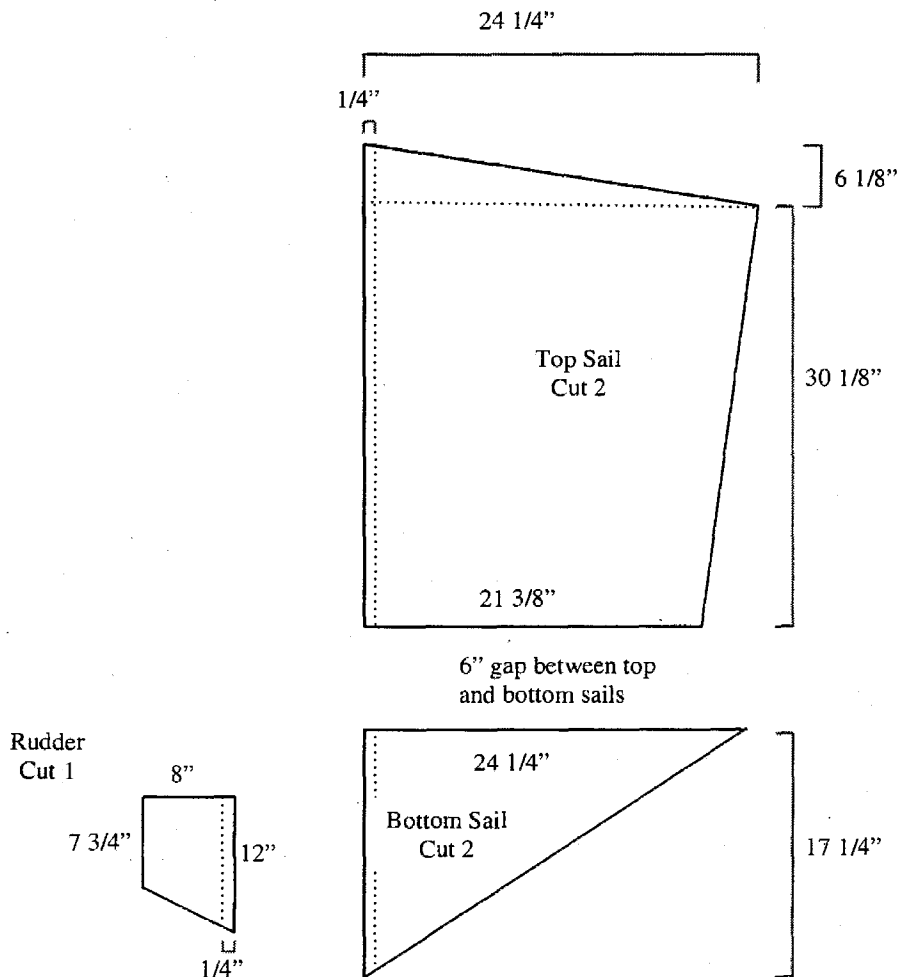

Top and Bottom sails can be in either 1 or 2 pieces to accommodate graphic.

Rudder is typically sandwiched in bottom sail center seam, but may be suspended by cords if graphics require it.